



Multichannel temperature sensor controller MKDT-51

USER MANUAL

Content

| | |
|---|----------|
| 1 Product Description | 3 |
| 1.1 Purpose of the product | 3 |
| 1.2 Technical specifications | 3 |
| 1.3 Completeness | 4 |
| 1.4 Installation procedure | 5 |
| 2 Maintenance | 6 |
| 3 Storage and transportation rules | 6 |
| 4 Manufacturer's (supplier's) warranties | 6 |

1 Product Description

This manual contains information on the purpose, technical characteristics, installation procedure and safe operation of the temperature controller "MKDT-51" (hereinafter referred to as the device) and is intended for service personnel.

1.1 Purpose of the product

The device is designed for continuous operation as part of the Jcom-IoT production monitoring system.

The device is designed to poll 15 temperature sensors with data transmission (temperatures) to the RS-485 network upon request from another device.

Device allows connection 15 remote sensors temperatures ASNB.468266.021.

1.2 Technical specifications

Device supply voltage:

- on the "+12V" contacts, "-12V" + 9.0...+12.0V

Device provides given environmental parameters at following conditions:
tions:

- ambient temperature air -20°C..+40°C;
- air humidity at +25°C (30..80)%;
- atmospheric pressure (84..100) kPa.

The serial interface data transfer rate is 9600 bps. Current consumption is no more than 70 mA.

Mounts on a 35mm DIN rail. Can be positioned anywhere. Mean time between failures (MTBF) of at least 150,000 hours.

Service life is 20 years.

The weight of the device is no more than 0.25 kg.

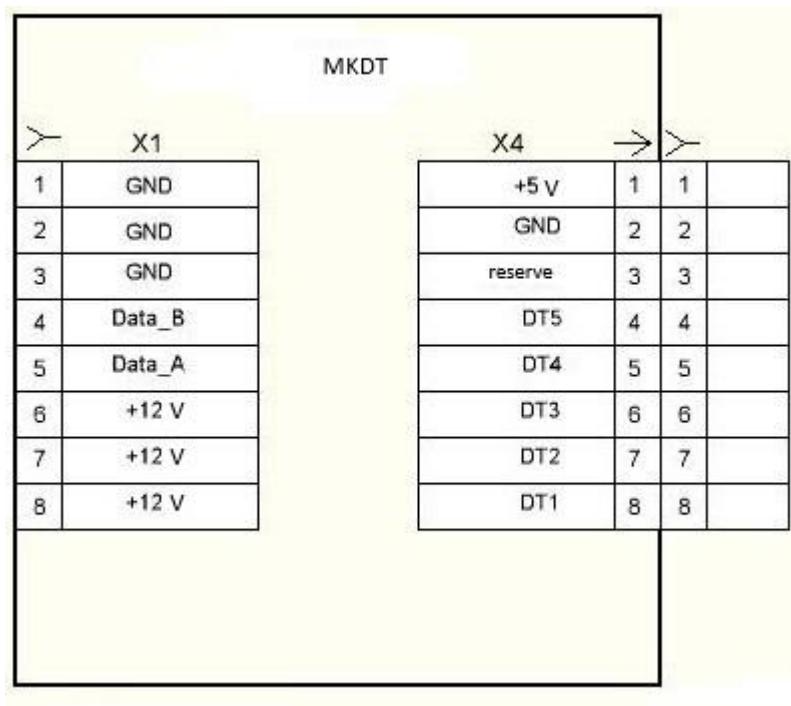

Figure 1.

The type and purpose of the device terminals are shown in Table

1. Table 1

| Output name | Output type | Purpose of the output | Number of pins |
|-------------|---------------|-----------------------------|----------------|
| X1 - 1,2,3 | in | Controller power supply "-" | 3 |
| X1 - 4 | in/out | RS-485 Data "B" | 1 |
| X1 - 5 | in/out | RS-485 Data "A" | 1 |
| X1 - 6,7,8 | in | Controller power supply "+" | 3 |
| | | | |
| X4 - 1 | in | Controller power supply "+" | 1 |
| X4 - 2 | in | Controller power supply "-" | 1 |
| X4 - 3 | -- | Reserve | 1 |
| X4 - 4 | in/out | DT5 sensor data line | 1 |
| X4 - 5 | in/out | DT4 sensor data line | 1 |
| X4 - 6 | in/out | DT3 sensor data line | 1 |
| X4 - 7 | in/out | DT2 sensor data line | 1 |
| X4 - 8 | in/out | DT1 sensor data line | 1 |

1.3 Completeness

| | |
|----------------|-------------|
| MKDT-51 device | 1 pc. |
| User manual | 1 piece/lot |
| Label | 1 piece/lot |
| Package | 1 piece/lot |

Note: The batch size is determined by the manufacturer.

1.4 Installation procedure

CAUTION: If signals containing hazardous voltage are connected to the device, all installation work must be carried out with the power disconnected.

When carrying out installation and commissioning works, it is necessary to use the design documentation for the monitoring system.

Install the device on a DIN rail.

The device communicates via the RS-485 interface using a two-wire circuit. Connection should be made using twisted-pair wires, observing polarity. Wire A is connected to the A terminal of the device, and wires B are connected similarly. Connection must be made with both devices powered off.

Connect the temperature sensor(s) as shown in Figure 2.

No more than 3 sensors can be connected to one data line.

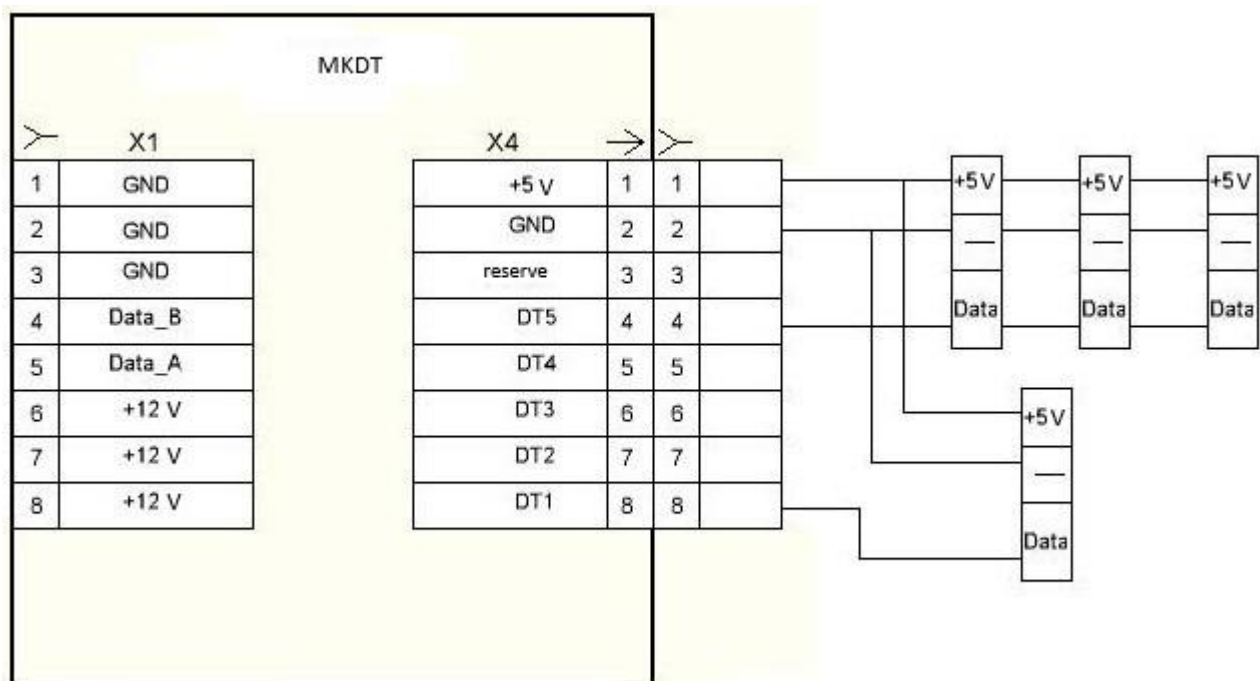

Figure 2. Example of connecting 4 sensors.

2 Maintenance

During operation of the unit during its service life, no maintenance work is required.

3 Storage and transportation rules

Climate conditions transportation should correspond next conditions:

- ambient air temperature from minus 50°C to plus 50°C;
- relative air humidity up to 98% at 25°C;
- atmospheric pressure from 84.0 to 107.0 kPa (from 630 to 800 mmHg).

The devices can be transported by all types of transport (in covered wagons, closed vehicles, containers).

Devices should be stored only in the manufacturer's packaging in heated rooms at temperatures ranging from +5°C to +40°C and relative humidity no more than 80%. Storage areas must be free of aggressive impurities (such as acid or alkali vapors) that could cause corrosion.

4 Manufacturer's (supplier's) warranties

The warranty period is set at 12 months, counting from the date of transfer of the device to the buyer, subject to compliance with the conditions of transportation, storage, installation and operation.

During the warranty period, the manufacturer has the right to supervise the correct operation of the device in order to improve the quality and efficiency of operation.

Device components that fail during the warranty period are subject to replacement or repair by the manufacturer at the manufacturer's expense.

The user loses the right to free repairs during the warranty period in the event of broken seals, mechanical damage by the user, or if the device was repaired by a person who is not authorized to perform repairs and maintenance.