



STV-01 Precise Time Server

---

# USER MANUAL

Table of contents

- STV-01 Precise Time Server ..... 1**
- INTRODUCTION..... 3
- 1 DESCRIPTION AND OPERATION..... 4**
- 1.1 General information..... 4
  - 1.1.1 Server name ..... 4
  - 1.1.2 Server modification..... 4
  - 1.1.3 Server assignment..... 4
  - 1.1.4 Scope of application..... 4
  - 1.1.5 Server dimensions..... 4
  - 1.1.6 Server weight ..... 4
- 1.2 Technical specifications..... 4
  - 1.2.1 General information ..... 4
  - 1.2.2 Technical specifications ..... 5
  - 1.2.3 Resistance to external factors ..... 6
  - 1.2.4 Resistance to mechanical stress ..... 7
  - 1.2.5 Reliability..... 7
- 1.3 Server composition ..... 7
  - 1.3.1 Time server ..... 7
  - 1.3.2 GNSS signal receiver ..... 8
- 1.4 Installation and connection ..... 8
  - 1.4.1 Installation and dismantling..... 8
  - 1.4.2 Getting ready for work ..... 10
- 1.5 Working with the server..... 10
  - 1.5.1 General information ..... 10
  - 1.5.2 Front control panel ..... 10
  - 1.5.3 Indicators..... 11
  - 1.5.4 Liquid crystal display ..... 11
  - 1.5.5 Setting up STV via the front control panel..... 11
  - 1.5.6 Front panel navigation..... 12
- 2 DELIVERY KIT ..... 13**
- 3 MAINTENANCE ..... 13**
- 3.1 Checking server performance ..... 13
- 3.2 Technical inspection ..... 13
- 4 SAFETY INSTRUCTIONS ..... 13**
- 5 STORAGE..... 14**
- 5.1 Server storage conditions ..... 14
- 5.2 Shelf life ..... 14
- 5.3 Maximum shelf life..... 14
- 5.4 Rules for placing a server in storage ..... 14
- 5.5 Rules for removing a server from storage..... 14
- 6 TRANSPORTATION ..... 14**
- 6.1 Transportation conditions..... 14
- 6.2 Preparation for transportation ..... 14
- 7 DISPOSAL ..... 14**
- 8 WARRANTY OBLIGATIONS..... 15**
- Appendix A..... 16

## INTRODUCTION

This operating manual (hereinafter referred to as the "OM") contains general information intended to familiarize service personnel with the operation and operating rules of the STV-01 Precision Time Server (hereinafter referred to as the "server" or "STV-01"). This document contains technical specifications, a description of the design and operating principle, and information necessary for the proper operation of the server.

Before starting work, you must read this manual, since the server must be operated by persons familiar with the operating principle and design of the STV-01.

The server can be serviced by personnel with an electrical safety qualification group of at least the third.

Persons who have not passed the safety test in the prescribed manner are prohibited from working with the server.

When operating the server, personnel must follow the recommendations set out in the industry's static electricity protection guidelines.

It is prohibited to install or dismantle the server while the power is on.

The manufacturer reserves the right to make minor changes that do not degrade the server's technical specifications. Such changes may not be reflected in this document.

## **1 DESCRIPTION AND OPERATION**

### **1.1 General information**

#### ***1.1.1 Server name***

Precise time server STV-01.

#### ***1.1.2 Server modification***

– ASNB.428000.001-01 – for mounting in 19" racks and cabinets, height – 1U;

The STV-01 is equipped with various communication interfaces: Ethernet, RS-232, USB, and RS-422. The type and number of interfaces are specified at the time of order. The Ethernet interface is the primary operating interface, through which the STV-01 synchronizes time with devices connected to the local area network. The RS-232 interface is used for local server configuration, and the RS-422 interface communicates with the GNSS signal receiver.

The order code STV-01 with various options is given in Appendix A.

#### ***1.1.3 Server assignment***

Measuring (maintaining) current time and date values with synchronization using global navigation satellite systems (GNSS) signals and issuing current date/time values via network interfaces.

#### ***1.1.4 Scope of application***

The STV-01 is designed to operate as part of automated information and measuring systems for commercial electricity metering (AIMS KUE) for synchronizing current time and date values, as well as for synchronizing time scales of base communication stations and security systems at facilities in the security and industrial sectors.

#### ***1.1.5 Server dimensions***

The dimensions of the server in the ASNB.428000.001-01 modification are 500x300x50 mm.

#### ***1.1.6 Server weight***

For modification ASNB.428000.001-01 – no more than 5 kg.

### **1.2 Technical specifications**

#### ***1.2.1 General information***

The server complies with technical specifications TU 26.20.14-002-47212169-2022.

### 1.2.2 Technical specifications

The server specifications are given in Table 1. Table No. 1. Technical specifications

Parameter name	Meaning
Design	For mounting in 19" racks and cabinets, height – 1U
Supply voltage	from 100 to 264 V AC
Power consumption, no more than	20 W
operating system	Linux
Network interfaces (optional n is determined when ordering)	1) ETHERNET 1×NTP (10/100 Mbps) 2) ETHERNET n×NTP (10/100 Mbps)
Supported transport protocols	TCP, UDP
Supported network protocols	IPv4, IPv6
Supported network protocols	NTP, DHCP, NBNS
Supported time synchronization protocols (ETHERNET)	NTP v2 (RFC 1119), NTP v3 (RFC 1305), NTP v4 (RFC 5905), SNTP v3 (RFC 1769), SNTP v2c (RFC 1158), SNTP v4 (RFC 2030)
Output signal	1×PPS - seconds marker
Reference generator (specified when ordering)	1) TCHO (error ±1 ms/day) 2) OCXO-HQ (error ±5 μs/day) 3) Rubidium (error ±0.2 μs/day)
Server time STV-01	UTC+0 (GMT)
Built-in HTTPS web server for configuration	+
RS232 interface	1 pc.
USB interface	1) USB is missing 2) USB 1 pc. (Optional)
LCD/LED display for server status	+
Setting buttons on the front panel	+
Operating conditions of the control unit: – ambient air temperature, °C – relative air humidity at a temperature of +25 °C, %, no more than – atmospheric pressure, kPa	from 0 to +60  80 from 84 to 106.7
Receiver operating conditions: – ambient air temperature, °C – relative air humidity at a temperature of +25 °C, %, no more than – atmospheric pressure, kPa	from –40 to +60  98 from 84 to 106.7
Mean time between failures of STV-01	100,000 hours
Average service life	at least 20 years
GNSS signal receiver (specified when ordering)	1) GLONASS/GPS 2) GLONASS/GPS/BeiDou/Galileo
Overall dimensions of the GNSS signal receiver excluding the antenna and elements, no more than	150x90x70mm
Communication interface between the control unit and the GNSS signal receiver	RS-422 (with galvanic isolation)
Protection class of the GNSS signal receiver housing	IP65
GNSS antenna for outdoor mounting (with mounting kit) (specified when ordering)	1) ICB ANT GNSS (from -40 to +85 °C) 2) GPS-P (from -70 to +90 °C)
Interface cable(specified when ordering)	1) 20 meters 2) Up to 500 meters
Antenna cable(specified when ordering)	1) 0.6 meters 2) Up to 100 meters

Overall dimensions of the STV block (W×D×H), mm, no more than	500×300×50
Weight, kg, no more than	5

### 1.2.3 Resistance to external factors

Normal operating conditions for the server are:

- ambient air temperature from 0 to +60 °C;
- relative air humidity 80% at a temperature of +25 °C;
- atmospheric pressure from 84 to 106.7 kPa (from 630 to 800 mmHg).

Normal operating conditions of the receiver are:

- ambient air temperature from -40 to +60 °C;
- relative air humidity 98% at 25 °C;
- atmospheric pressure from 84 to 106.7 kPa (from 630 to 800 mm Hg Art.).

The diagram shows the possible arrangement of devices in different temperature ranges:

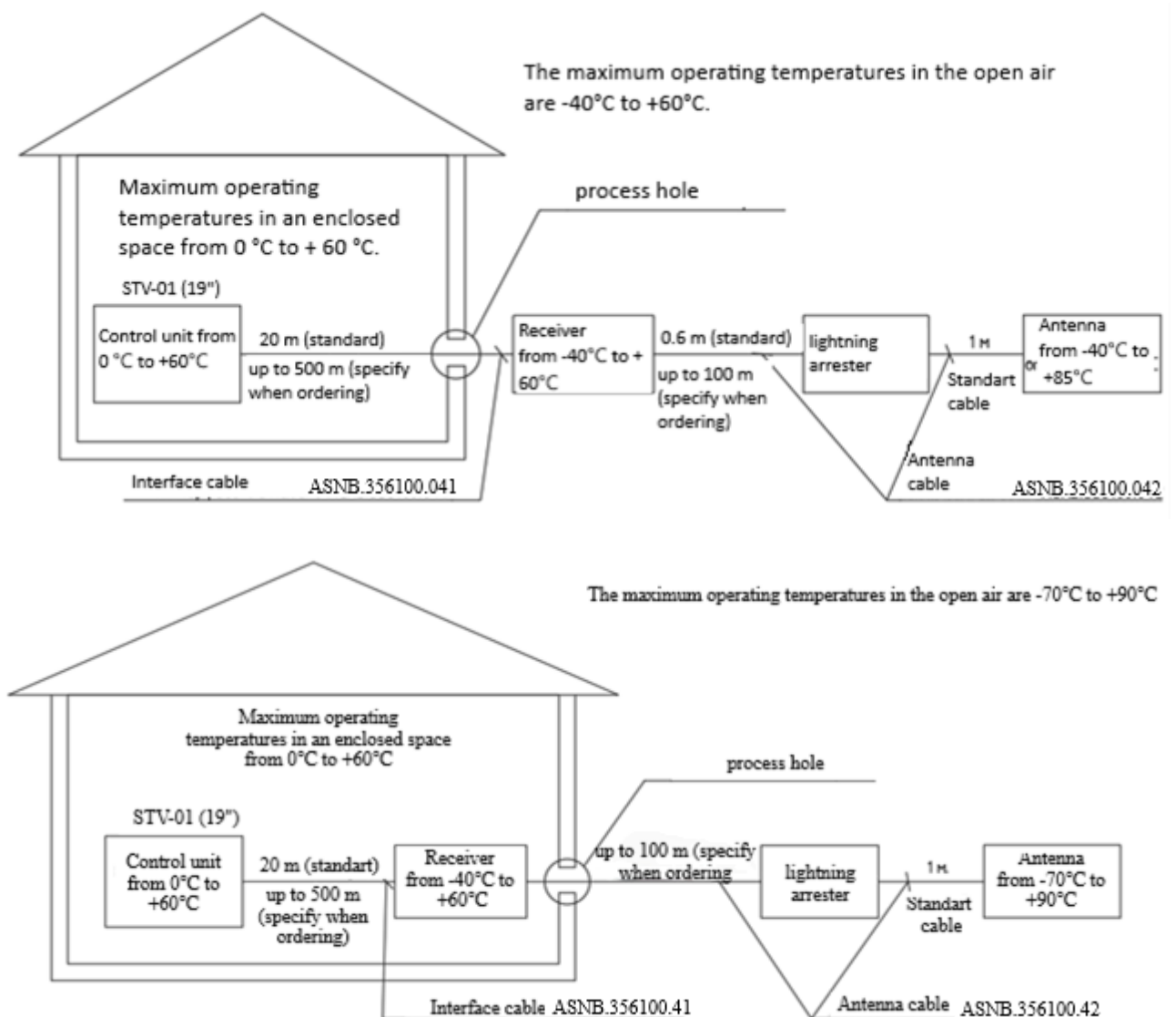

Figure 1.1 Connection of STV-01(19'') in different temperature ranges.

### 1.2.4 Resistance to mechanical stress

The server components meet the mechanical vibration resistance requirements in accordance with Table 2.

Table 2. Impact load characteristics

Impact characteristics	Direction of blows		
	Vertical loads	Horizontal loads	
		longitudinal	transverse
Number of strokes	2000	200	200
Peak shock acceleration, g	15	12	12
Duration of the shock acceleration, ms	5-10	2-15	2-15
Number of beats per minute	200	200	200

### 1.2.5 Reliability

The server provides a mean time between failures of 100,000 hours.

The server provides an average recovery time of no more than 1 hour. The average service life is at least 20 years, including maintenance. The average storage period (before commissioning) is 12 months.

## 1.3 Server composition

The STV-01 (19") precision time server structurally consists of the following units, connected to each other by cables:

- The control unit, housed in a metal case, is placed in a telecommunications cabinet and is marked "Precise Time Server STV-01";
- GNSS signal receiver in a protected all-weather housing;
- GNSS antenna.

### 1.3.1 Time server

The front panel of the time server STV-01(19") is shown in Fig. 1.2.



Figure 1.2. Front panel of the control unit STV-01 (19")

The "Network" button turns the device on/off; when turned on, it lights up red.

Three LED indicators display the operating modes of the time server:

- "Power" - indicates the server is on.

- “GPS/GLONASS” - indicates the reception of signals from the corresponding navigation satellite systems; the absence of an indicator means there is no signal or the external module is not connected.
- "Autonomous operation" means the server is operating autonomously, i.e. its own clock is not synchronized with the time of satellite navigation systems for more than 3 hours.

The two-line liquid crystal display shows the current server date and time in UTC format.

The "Ethernet" connector is designed to connect the server to a local Ethernet network.

The "RS232" connector is intended for local configuration of the server via the RS-232 serial interface.

On the rear panel of the device there is a power connector for connection to a ~220V network and a connector for connecting an RS-422 connecting cable for communication with the remote receiver module.

### ***1.3.2 GNSS signal receiver***

The remote module is a GNSS signal receiver housed in a weatherproof IP65 aluminum enclosure. The remote module requires no setup or configuration.

## **1.4 Installation and connection**

### ***1.4.1 Installation and dismantling***

Only persons with a qualification group in electrical safety of at least the third level, who have completed a training course and received the appropriate certificate, are allowed to install, configure, and maintain the server.

The server should be installed in industrial premises with an atmosphere free of chemically active or aggressive vapors and conductive dust, with a dust content of no more than 3 mg/m<sup>3</sup>, in locations protected from direct sunlight and water. Typically, the server should be housed in a heated room in a dedicated cabinet.

The server enclosure is designed for installation in 19" rack rails. Once the server is installed, external connection cables are connected to it. Cable connections are made using screw clamps.

The GNSS antenna must be mounted outdoors, ensuring that the antenna mounting point provides a clear view of the sky with a viewing angle of at least 120 degrees (open sky). The antenna should not be installed in the main lobe of other transmitting antennas. The distance to the nearest objects in the upper hemisphere must be at least 0.5 m.

Water from the roof should not drip onto the antenna or cables. After connecting the cable to the antenna, seal the connector joints with waterproof seals or adhesive tape.

The antenna must be installed in the lightning protection zone and have an external lightning arrester.

The lightning arrester should be grounded using a separate copper busbar with a cross-section of at least 4 mm<sup>2</sup>, insulated from the lightning rod. The antenna placement diagram is shown in Figure 3.1.

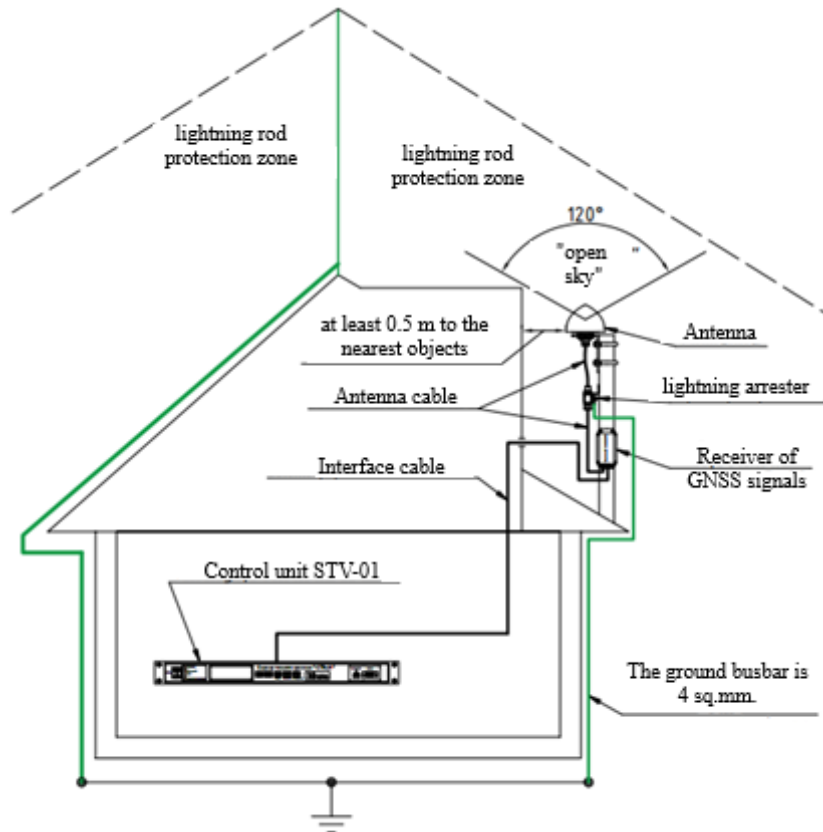

Figure 3.1 Antenna placement diagram

The connection diagram of the nodes is shown in Figure 3.2.

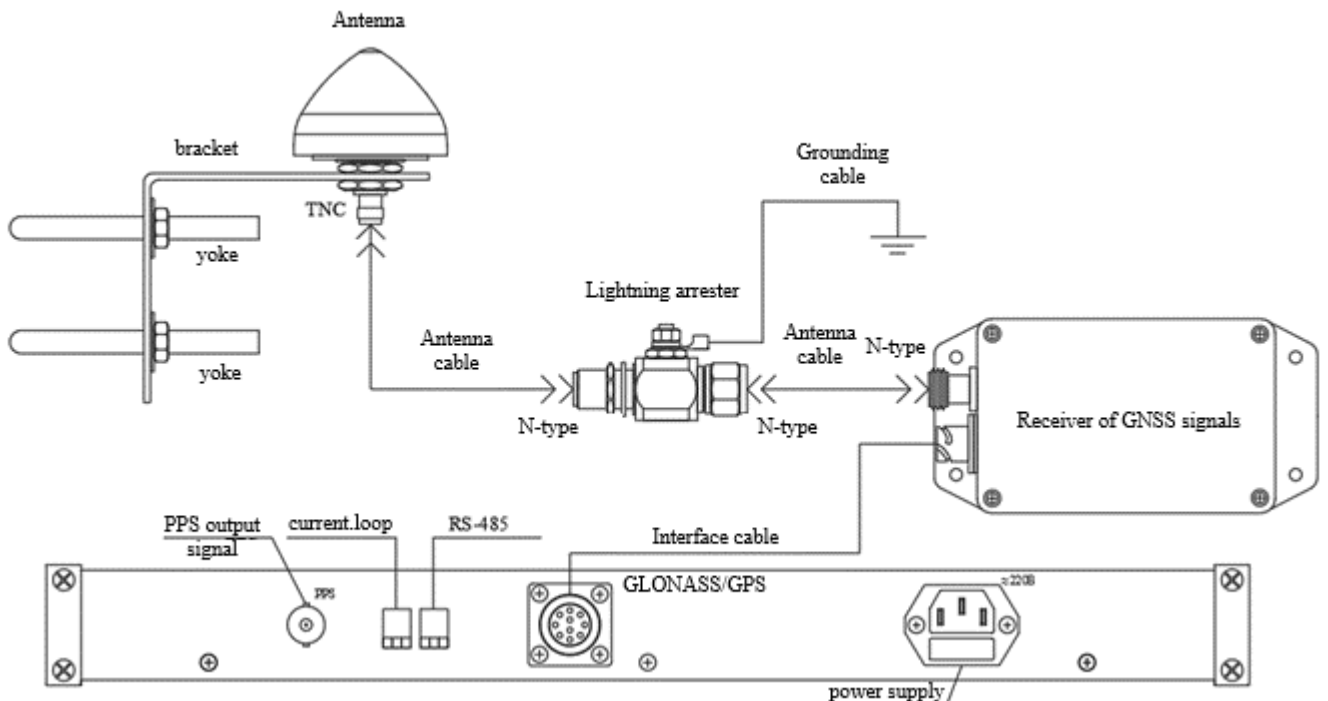

Figure 3.2 Connection diagram of STV-01 (19'') units.

The lightning arrester bracket is attached using a screw, bolt, or clamp. Figure 3.3. The antenna bracket is attached using U-shaped clamps and can be secured to a pipe with a diameter of 20 to 27 mm (3/4"). Antenna mounting options are shown in Figure 3.4.

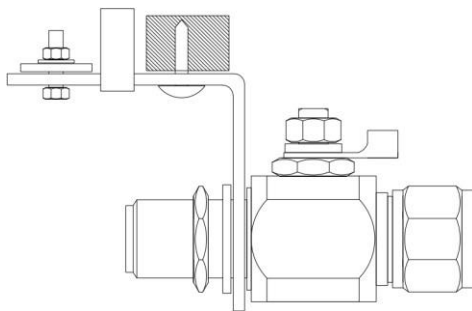

Figure 3.3 Fastening the lightning arrester

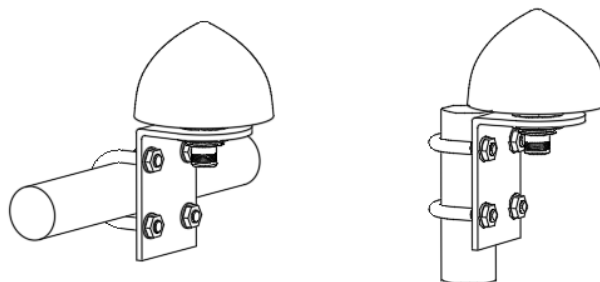

Figure 3.4 Antenna mount

### ***1.4.2 Getting ready for work***

The server is fully ready for use as intended upon completion of installation and commissioning work.

Installation and commissioning works may be carried out by representatives of the manufacturer, authorized service centers and representatives of the Customer who have undergone training at the manufacturer.

When inspecting the server externally, you should check:

- completeness of STV-01 in accordance with the form (passport);
- absence of visible mechanical damage;
- cleanliness of sockets, connectors and terminals;
- condition of connecting wires, cables, adapters;
- condition of paint coatings and clarity of markings;

## **1.5 Working with the server**

### ***1.5.1 General information***

The server contains embedded software based on the Linux family. Four interfaces are available for device configuration:

1. Through the front panel.
2. Via the WEB interface for settings and management.
3. Via SNMP protocol.





It is worth noting that the most detailed configuration is possible only through the WEB interface.

The NTP server (STV-01) does not have a time zone setting. The NTP server (STV-01) distributes time in UTC+0 (GMT).

The time zone is configured on the NTP client equipment; only in this case is correct time synchronization guaranteed.

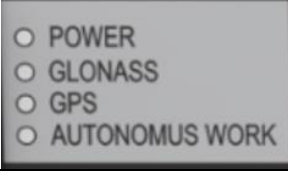
### ***1.5.2 Front control panel***

The front panel of the STV contains the following objects: LED indicator panel, push-button panel, interface panel, LCD/LED display and On/Off button:

	<p><b>LED indicator panel</b></p>
	<p><b>Pushbutton panel</b></p>
	<p><b>Interface panel</b></p>
	<p><b>LED display</b></p>
	<p><b>On/Off button</b></p>

### 1.5.3 Indicators

LED indicators display the operating modes of the time server:

- "Power" - indicates the server is on.
- "GLONASS", "GPS" - indicates the reception of signals from the corresponding navigation satellite systems; the absence of an indicator means there is no signal or an external module is not connected.
- "Autonomous operation" means the server is operating autonomously, i.e. its own clock is not synchronized with the time of satellite navigation systems for more than 3 hours.

### 1.5.4 Liquid crystal display

Line 1 - displays the time in [HH:MM:SS] format (GMT (Greenwich Mean Time)).

Line2 – Stratum NTP number

Line 3 - number of satellites, working group:

GLONASS+BeiDou/GPS/GLONASS/BeiDou



Figure 4 STV display

### 1.5.5 Setting up STV via the front control panel

Local configuration is performed via the front control panel. During operation, the screen displays

current information.

Through the front panel, you can configure the Eth0 interface parameters: IP address, subnet mask and gateway, as well as reset the settings to default settings.

Pressing the "F1" button switches the screen to the setup mode, where you can set the IP address of the eth0 interface, mask and gateway, and reset the device settings to default values.

Default device settings:

GLONASS+Beidou

IP 192.168.1.136

### 1.5.6 Front panel navigation

To enter the settings mode, use the "F1" button.

Next, the "F1" button is used to scroll through the settings pages.

The following settings are available to the user for configuration:

- 1) 'eth0 IP' - Ethernet address

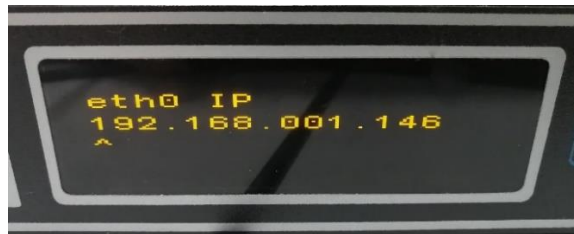

Figure 5 Ethernet Address

- 2) 'eth0 MASK' - Ethernet network mask



Figure 6 Ethernet Network Mask

- 3) 'eth0 GTWAY' - Ethernet gateway

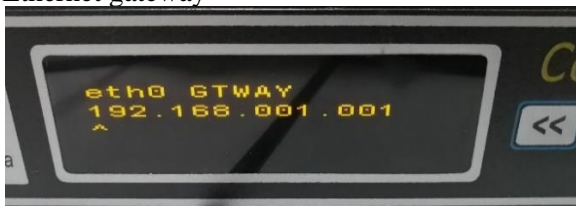

Figure 7 Ethernet Gateway

- 4) 'Restore defaults' - reset the above settings to default

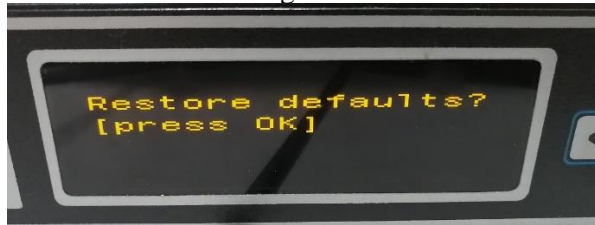





Figure 8 Resetting the above settings

The parameters are configured as follows:

- 1) keys   move the cursor to the left and right by individual characters, respectively;
- 2) the "OK" key activates the value editing mode (indicated by the appearance of the '(edit)' field in

the top line);

3) in 'edit' mode keys   decrease/increase the value by 1 (the maximum value of an individual field is limited to 255);

4) the "OK" key confirms the new value and turns off the editing mode; instead of "OK", you can press "X" to cancel the latest changes;

5) To apply a new parameter, use the "F1" key. Then, when the clarifying message 'Apply changes?' appears, the "OK" key confirms the new parameter, and "X" cancels all changes to the parameter;

6) After making a selection, the "F1" key is again used to scroll through pages.

Restore defaults (restore default settings).

1) the "OK" button displays a clarifying message to the user: 'Are you sure?'

“OK” confirms the choice (the system then reboots), and “X” cancels it.

To exit the settings mode, press the "X" key, and the user will be prompted to apply the new parameters if changes have occurred.

Changing any Ethernet network settings parameter and then exiting the settings mode causes the system to automatically reboot.

The settings session automatically ends if there are no key presses for 30 seconds.

## 2 DELIVERY KIT

Name	Quantity
Time server	1 pc.
GNSS receiver	1 pc.
GNSS antenna with bracket	1 pc.
Lightning arrester with cable	1 pc.
Network cable	1 pc.
Antenna cable	1 pc.
Interface cable	1 pc.
STV-01 Time Server. Operation Manual	1 copy per batch
Time server STV-01. Passport	1 copy
Note: The batch and execution are determined when ordering.	

## 3 MAINTENANCE

### 3.1 Checking server performance

The server's operability criterion is the output of time information to the liquid crystal display and to the Ethernet network using the NTP and SNTP protocols.

### 3.2 Technical inspection

The server operated as part of an automated system is subject to sealing by an authorized representative of the Customer from the moment the system is put into operation.

The sealed server is subject to periodic inspection by authorized representatives of the Customer to ensure the integrity of the seals. The frequency of inspection is determined by the Customer. The inspection results may be recorded in the server's logbook.

## 4 SAFETY INSTRUCTIONS

When carrying out work, the “Inter-industry rules for labor protection (safety rules) during the operation of electrical installations” POT R M-016-2001 (RD 153-34.0-03.150-00) must be followed.

Before turning on the STV-01 time server, the electrical outlet it is connected to must be grounded. Grounding must be accomplished using a cable with a cross-section no smaller than the power cable.

When performing certain types of routine maintenance work on the STV-01, the following precautions must be observed:

- 1) All installation and dismantling work must be carried out with the supply and input voltages disconnected;
- 2) avoid touching live circuits with a voltage of ~220 V located in the area of the primary power source of the unit;

## **5 STORAGE**

### **5.1 Server storage conditions**

The server must be stored under conditions according (closed or other premises with natural ventilation without artificially controlled climate conditions) at a temperature from minus 40 °C to plus 60 °C and a relative humidity of no more than 90% (at plus 25 °C).

The air in the server storage room must not contain aggressive impurities (acid vapors, alkalis). Storage requirements apply to the supplier's and consumer's warehouse premises.

### **5.2 Shelf life**

The shelf life of the server in consumer packaging without re-preservation is at least 1 year.

### **5.3 Maximum shelf life**

For long-term storage (more than 1 year), the server must be packaged and kept in heated storage facilities for no more than 3 years at an ambient temperature of plus 5°C to plus 40°C and a relative humidity of no more than 80% at a temperature of plus 25°C.

### **5.4 Rules for placing a server in storage**

When storing a server for a long period of time, it must be packed in the supplier's packaging.

### **5.5 Rules for removing a server from storage**

There are no restrictions or special procedures for removing a server from storage. When removing a server from storage, it should be removed from its packaging.

## **6 TRANSPORTATION**

### **6.1 Transportation conditions**

Servers may be transported in shipping containers by all modes of transport (including in heated, sealed aircraft compartments, with no distance restrictions). When transported in railcars, the shipment must be small, low-tonnage.

When transporting the server, ensure protection from dust and precipitation. Do not tilt the server.

### **6.2 Preparation for transportation**

The server must be secured to ensure stability and prevent mutual displacement and impact. Handling signs on the shipping container must be strictly observed during loading, unloading, and transportation.

## **7 DISPOSAL**

The server does not contain any hazardous or toxic substances that could harm human health or the environment and does not pose a risk to life, human health, or the environment at the end of its service life. Therefore, the server can be disposed of according to general industrial waste disposal regulations. The server components (electronic boards, connectors, etc.) contain very low levels of precious metals, making recycling them impractical.

## **8 WARRANTY OBLIGATIONS**

The warranty period is 12 months from the date the product is delivered to the buyer. The warranty does not cover defects resulting from improper handling, maintenance, storage, or transportation.

Order code STV-01

Product type	Frame	Receiver	Antenna	Generator	Interface	USB	Exit	power unit	Interface cable	Antenna cable	Option
STV-01	19										19" mount, 1U
		PR1									GLONASS/GPS signals
		PR2									GLONASS/GPS/BD/Galileo signals
			A1								ICB ANT GNSS Temperature -40...+85 °C
			A2								GPS-P Temperature -70...+90 °C
				G1							TCXO (error ±1 ms/1 day)
				G2							OCXO-HQ (error ±5 µs/1 day)
				G3							Rubidium generator (error ±0.2 µs/1 day)
					I1						Ethernet: 1xNTP (10/100Mbps) (standard)
					In						Ethernet: nxNTP (10/100Mbps)(optional)
						U0					None (standard)
						U1					1 pc (optional)
							B1				Output frequency signals: 1xPPS
								P220			Main power supply 220V AC
									KI20		20 meters
									KIKHHH		Up to 500 meters (specify when ordering)
										KA0.6	0.6 meters
										KAHHHH	Up to 100 meters (specify when ordering)

**Example:**STV-01.19.PR1.A1.G1.I1.U0.V1.P220.KI20.KA0.6 (Basic configuration)