



PTP Converter

---

# USER MANUAL

## Content

INTRODUCTION	2
1 DESCRIPTION AND OPERATION	4
1.1 General information	4

1.1.1 General structural diagram	4
1.1.2 Purpose of the product	4
1.1.3 General appearance of the product	6
1.2 Technical characteristics	7
1.3 Completeness devices IS-02	7
1.4 Front panel "IS-02"	8
1.5 Installation and connection	9
1.5.1 Installation and dismantling	9
1.5.2 Preparation for work	9
1.6 Working with the product	9
1.6.1 General information	9
1.6.2 Description of the front panel	9
1.6.3 Configuring devices via the front control panel	<b>Ошибка! Закладка не определена.</b>
1.6.4 Navigating via the front panel	10
1.7 Device indicators	11
2 MAINTENANCE	12
2.1 Product maintenance	12
2.2 Technical inspection	12
3 SAFETY INSTRUCTIONS	12
4 STORAGE	13
4.1 Storage conditions of the product	13
4.2 Storage period	13
4.3 Maximum shelf life	13
4.4 Rules for storing the product	13
4.5 Rules for removing the product from storage	13
5 TRANSPORTATION	13
5.1 Transportation conditions	13
5.2 Preparation for transportation	13
6 DISPOSAL	13
7 WARRANTY OBLIGATIONS	14

## INTRODUCTION

This operating manual (hereinafter referred to as the "OM") contains general information intended to familiarize service personnel with the operation and operating procedures of the "IS-02 Synchronization Source" device (hereinafter referred to as the "product"). This document contains technical specifications, a description of the design and operating principle, and information necessary for the proper operation of the product.

Before starting work, please read this manual, as the product must be operated by persons familiar with the operating principle and design of the product.

The product can be serviced by personnel with an electrical safety qualification group of at least the third.

Persons who have not passed the safety test in the prescribed manner are prohibited from working with the product.

During operation of the product, personnel must follow the recommendations set out in the industry instructions for protection against static electricity.

It is prohibited to install or dismantle the product when the power supply is turned on.

The manufacturer reserves the right to make minor changes that do not degrade the product's technical specifications. Such changes may not be reflected in this document.

# 1 DESCRIPTION AND OPERATION

## 1.1 General information

### 1.1.1 General structural diagram

The principle of constructing a common synchronization network of base stations using IS-02 is shown in Figure 1.

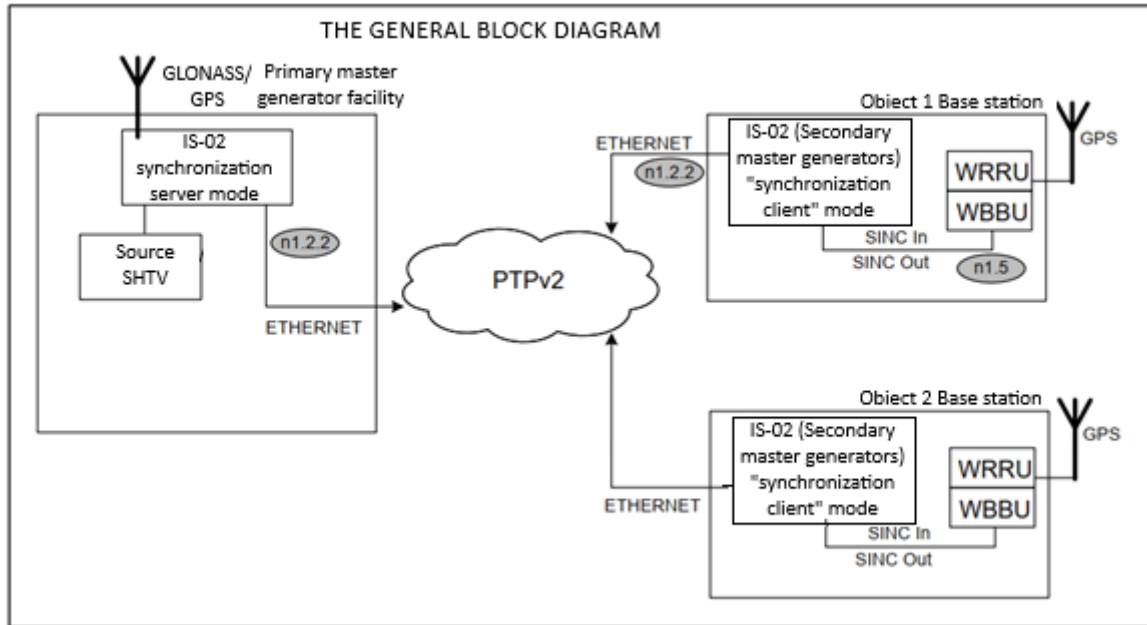

Figure 1 General structural diagram

### 1.1.2 Purpose of the product

**Purpose of "IS-02" in the PZG (Primary Master Oscillator) mode**– synchronization of "IS-02" VZG located at the operator's facilities.

**Purpose of "IS-02" in the VZG (Secondary Master Oscillator) mode**- generation of synchronization signals for the WBBU module at base stations (BS). A high-precision built-in generator ensures the synchronization signal supplied to the BS remains stable at no worse than 1  $\mu$ s for two days in the event of loss of connection between the BS and the network core (due to a transport accident).

At the facility, the BS VZG ensures the formation of synchronization pulses for the "SYNC IN+" and "SYNC IN -" inputs of the WBBU module.

The device generates output signals "SyncOUT+", "SyncOUT-" to synchronize the WBBU module.

Pulses with an amplitude of 3 volts and a period of 10 ms. The length of the 99th pulse is 2 ms (with an 8 ms pause). The length of the 100th pulse is 6 ms (with a 4 ms pause). Thus, pulses with a duration of 6 ms are repeated every second. For "SyncOUT+", these pulses have an amplitude of +3 V, and for "SyncOUT-", -3 V. The leading edge of the first "SyncOUT+" pulse (6 ms duration) is tied to the device's time base (specifically, to the leading edge of the 1 PPS signal - "PPS.Gen").

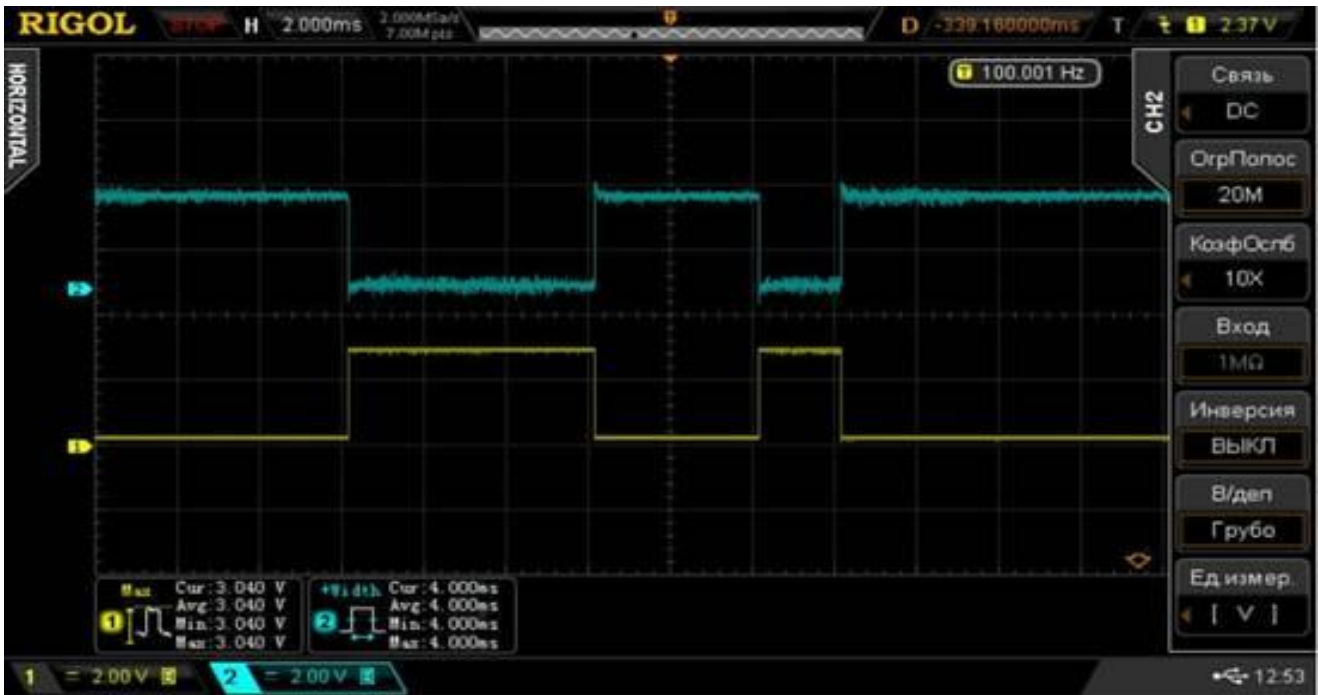

Figure 2

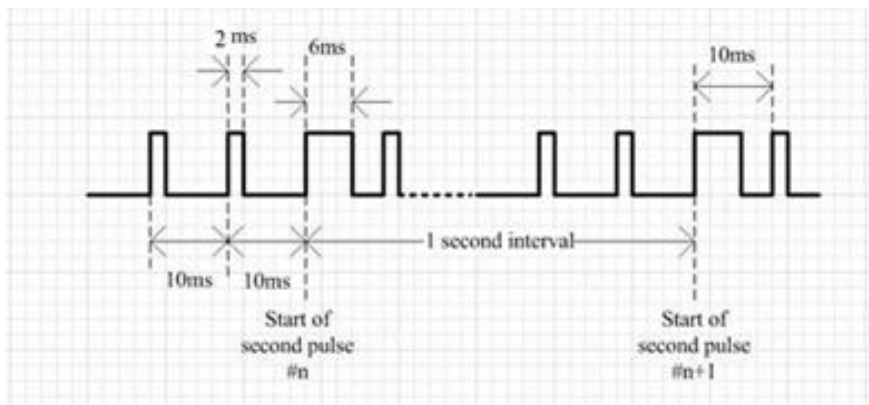

Figure 3

In the absence of synchronization with external sources (PTP v2), the device continues to generate output signals “SyncOUT+”, “SyncOUT-“ from the clock signals of the generator in the mode without external synchronization.

The SyncOUT generation unit is synchronized with a highly stable oscillator. The oscillator adjusts as data accumulates.

Does not have a built-in GLONASS/GPS/Beidou/Galileo receiver.

Does not have a built-in battery pack.

The built-in synchronization unit is designed to generate and transmit synchronization signals between objects: the central node (PZG) and the BS (VZG) via PTPv2.

The synchronization unit within the VZG operates in the synchronization client mode.

### 1.1.3 General appearance of the product



Figure 4 General view of the IS-02



Figure 5. Reverse side of the IS-02

## 1.2 Technical characteristics

Technical characteristics of the product are given in Table 1.

Table No. 1. Technical characteristics

Name of the characteristic	Meaning
Design	19" rack mount case
Voltage of the alternating current power supply network of the IS-01 complex VZG input "36-72 VDC"	36-72 VDC
operating system	Linux
Limits of permissible absolute error in the generation of synchronization signals in the absence of correction using signals from reference sources (autonomous operation)	no more 1 $\mu$ s/for 2 days
Network interfaces	1 Ethernet 10/100/1000 port
Output signal 1PPS – "Sync(PPS)"	SMA female connector on the front panel
Output signals "SyncOUT+", "SyncOUT-" to synchronize the WBBU module	SMA female connector on the front panel
Web interface for device configuration	+
RS232 interface	for debugging
LCD display for displaying the status of the "IS-02" and device settings	+
Setting buttons on the front panel	+
Overall dimensions excluding antenna and elements	255×480×45 mm

## 1.3 Completeness devices IS-02

Table No. 2. Completeness for the VZG object

No.	Name of the characteristic	Quantity
1	Device IS-02	1 piece
2	Power cable	1 piece
3	User manual	1 copy per batch
4	Passport	1 copy
Note: The batch is determined when ordering.		

## 1.4. Frontpanel "IS-02"

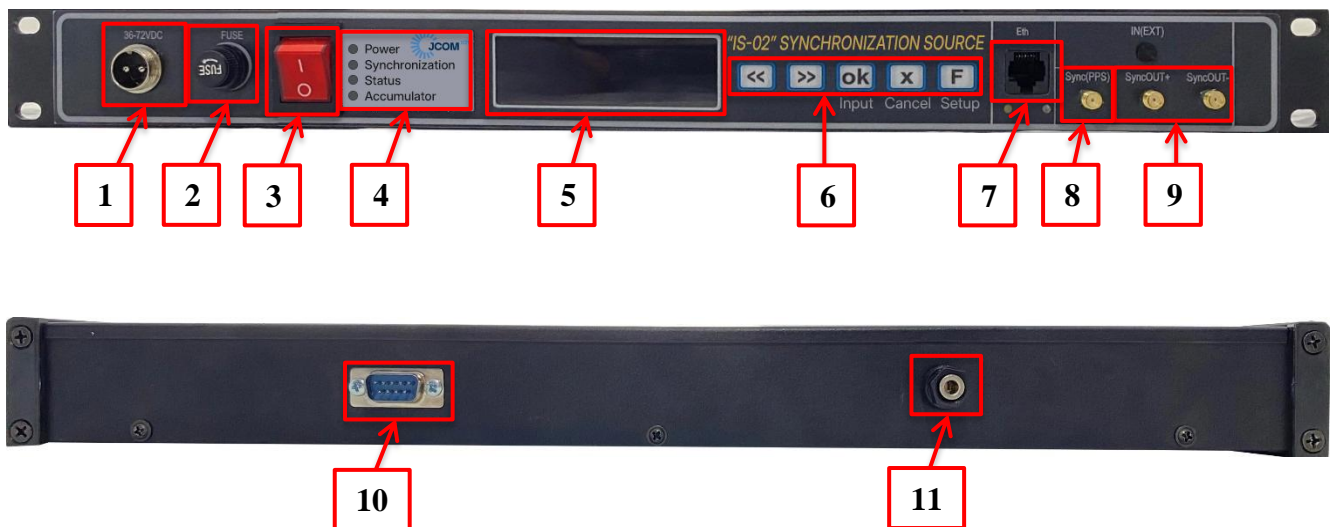

Figure 6 Front and rear panels of the IS-02

- 1) **connector** for power input.
- 2) **Fuse holder "FUSE"** to protect power supply circuits.
- 3) **Button** To turn the device on/off. When on, it lights up red.
- 4) **LED indicator panel**
- 5) **Three-line liquid crystal display** Displays the GNSS OK/BAD status, the number of satellites, the GPS/GLONASS/GPS+GLONASS/GPS+BeiDou constellation, and the antenna voltage in the top line. The second line displays the GNSS-REF and PTP-REF. The third line displays the Software/Firmware version.
- 6) **Control buttons** device.
- 7) **Ethernet connector** designed to connect the device to a local Ethernet network.
- 8) **Sync(PPS) connector** designed to output the PPS synchronizing signal.
- 9) **SyncOUT+ and SyncOUT- connectors** are designed to output synchronization signals from the WBBU module.

On the back panel are located

- 10) **RS232 connector** designed for local configuration of the IS-02 via a serial interface of the RS-232 standard (standard pinout).
- 11) **Terminal grounding**

## **1.5 Installation and connection**

### **1.5.1 Installation and dismantling**

Only persons with a qualification group in electrical safety of at least the third level, who have completed a training course and received the appropriate certificate, are allowed to install, adjust and maintain the product.

The product should be installed in industrial premises with an atmosphere free of chemically active or aggressive vapors and conductive dust, with a dust content of no more than 3 mg/m<sup>3</sup>, in locations protected from direct sunlight and water. Typically, the product is installed in a heated room in a dedicated cabinet.

The product enclosure is designed for installation in 19" telecommunications cabinet rails or on a wall. After installation, external connection cables are connected to the product. The cables are wired using screw clamps.

### **1.5.2 Preparation for work**

The product is completely ready for its intended use upon completion of installation and commissioning works.

Installation and commissioning works may be carried out by representatives of the manufacturer, authorized service centers and representatives of the Customer who have undergone training at the manufacturer.

When inspecting the product externally, you should check:

- completeness of the product in accordance with the form (passport);
- absence of visible mechanical damage;
- cleanliness of sockets, connectors and terminals;
- condition of connecting wires, cables, adapters;
- condition of paint coatings and clarity of markings;
- absence of detached or poorly secured product modules (determined visually or audibly when changing the position of the product).

## **1.6 Working with the product**

### **1.6.1 General information**

The IS-02 has two Ethernet interfaces with hardware support for the PTP v2 protocol (eth0 and eth1). Using two interfaces may improve synchronization accuracy over the transport network. Currently, only the eth0 interface is enabled in the current configuration.

The device has an operating mode – VZG.

In VZG mode, synchronization is possible using both PTP v2 and data accumulation for oscillator correction.

The generator is adjusted at a specified period. The adjustment requires exceeding a minimum percentage of accumulated data during this period and a maximum sample RMS value that does not exceed the value specified in the settings.

During manual synchronization, these criteria are ignored. It is assumed that the operator understands what they are doing and is responsible for their actions during manual configuration.

The product contains embedded software based on the Linux family. The following interfaces are available for device configuration:

1. Through the front panel.
2. Via the WEB interface for settings and management.

It is worth noting that the most detailed configuration is possible only through the WEB interface.

### **1.6.2 Description of the front panel**

The following objects are located on the front panel of the devices:

push button panel, LED indicator panel, LCD/LED display, interface panel and On/Off button:



**Power supply of the VZG unit device**

**Power connector, fuse holder, VZG power switch and LED indicator panel.**



**VZG display for device settings and viewing current statuses.**

Push-button panel for setting up the VZG device.



**The Ethernet connector is designed to connect devices to the local Ethernet network.**



The "Sync(PPS)" connector is designed for output PPS signal - Second mark synchronized with the device's internal time scale



The "SyncOUT+", "SyncOUT-" connectors are intended to output synchronization signals from the WBBU module



The RS232 connector is designed for terminal debugging of the IS-02 configuration via the RS-232 standard serial interface.

**1.6.3 Navigating via the front panel**

To enter the settings mode, use the 'F' key (the transition takes some time).

Next, 'F' is used to scroll through the settings pages.

The following settings are available to the user for configuration:

- 1) 'eth0 IP' - Ethernet address
- 2) 'eth0 MASK' - Ethernet network mask
- 3) 'eth0 GTWAY' - Ethernet gateway
- 4) 'Restore defaults' - reset the above settings to default

The parameters are configured as follows:

**- Ethernet:**

- 1) keys '<<' And '>>' move the cursor by individual characters to the left and right, respectively
- 2) The 'OK' key activates the value editing mode (indicated by the appearance of the '(edit)' field in the top line)
- 3) in the 'edit' mode, the keys '<<' And '>>' decrease/increase the value by 1 (the maximum value of an individual field is limited to 255)

**- General for Ethernet:**

- 1) The 'OK' key confirms the new value and turns off the editing mode; instead of 'OK', 'X' can be pressed to cancel the latest changes
- 2) to apply a new parameter, use the 'F' key;  
then, when the clarifying message 'Apply changes?' appears, the 'OK' key confirms the new parameter, and 'X' cancels all changes to the parameter
- 3) After making a selection, the 'F' key is again used to scroll through pages

**- Restore defaults (restore default settings)**

- 1) the 'OK' button displays a clarifying message to the user: 'Are you sure?'  
'OK' confirms the choice (then the system reboots), and 'X' cancels it.

To exit the settings mode, press the 'X' key, and the user will be prompted to apply the new parameters if changes have occurred.

Changing any Ethernet parameter and then exiting the settings mode causes the system to automatically reboot.

The settings session automatically ends if there are no key presses for 30 seconds.

## **1.7 Device indicators**

- 1) "Power" indicator:

This indicator lights green when the device is receiving external power.

- 2) "Synchronization" indicator – based on the collected data and the generator correction percentage, the output signals "SyncOUT+", "SyncOUT-" begin to form, and the "Synchronization" indicator turns on.

- 3) "Status" indicator: this is the "ALARM" signal – the indicator turns on if there has been no synchronization for 2 days (configured via the WEB).

- 4) Gigabit Ethernet LAN port indicators

- The indicator on the left below the LAN port lights yellow when the port is connected to a 100Mbps FastEthernet station. A blinking indicator indicates that the port is receiving or transmitting data to the network.

- The indicator on the right below the LAN port lights green when the port is connected to a 1000 Mbps Ethernet station. A blinking indicator indicates that the port is receiving or transmitting data to the network.

## **2 MAINTENANCE**

### **2.1 Product maintenance**

Periodic remote monitoring of the product's performance is recommended.

The device's hardware is equipped with a rechargeable battery that maintains the built-in clock when the external power supply is disconnected. The battery is guaranteed to last for at least 10 years when the device is in operation.

In the absence of external power supply, the battery's operability is guaranteed for:

- at least 1 year at a storage temperature of minus 40°C;
- at least 6 years when stored at a temperature of plus 25°C;
- at least 1 year when stored at a temperature of plus 85°C.

The stated battery lifespans determine the replacement intervals based on the operating conditions of the product. Battery replacement does not constitute product repair and is not covered by the manufacturer's or supplier's warranty.

### **2.2 Technical inspection**

The product used as part of an automated system is subject to sealing by an authorized representative of the Customer from the moment the system is put into operation.

Sealed products are subject to periodic inspection by authorized representatives of the Customer to ensure the integrity of the seals. The frequency of inspections is determined by the Customer. Inspection results may be recorded in the product's logbook (passport).

## **3 SAFETY INSTRUCTIONS**

Before turning on the IS-02 synchronization source, the electrical outlet it is connected to must be grounded. Grounding must be accomplished using a cable with a cross-section no smaller than the power cable.

When performing certain types of routine maintenance work on the IS-02, the following precautions must be observed:

- 1) all installation and dismantling work must be carried out with the supply and input voltages disconnected;
- 2) avoid touching live circuits with a voltage of ~220 V located in the area of the primary power source of the unit;

## **4 STORAGE**

### **4.1 Storage conditions of the product**

The product must be stored in closed or other rooms with natural ventilation without artificially controlled climate conditions at a temperature from minus 40°C to plus 60°C and a relative air humidity of no more than 90% (at plus 25°C).

The air in the room where the product is stored must not contain aggressive impurities (acid or alkali vapors).

Storage requirements apply to the supplier's and consumer's warehouse premises.

### **4.2 Storage period**

The shelf life of the product in consumer packaging without re-preservation is at least 1 year.

### **4.3 Maximum shelf life**

For long-term storage (more than 1 year), the product must be packaged and kept in heated storage facilities for no more than 3 years at an ambient temperature of plus 5°C to plus 40°C and a relative humidity of no more than 80% at a temperature of plus 25°C.

### **4.4 Rules for storing the product**

When placing the product into long-term storage, it must be packed in the supplier's packaging container.

### **4.5 Rules for removing the product from storage**

There are no restrictions or special procedures for removing the product from storage. When removing the product from storage, remove it from its packaging.

## **5 TRANSPORTATION**

### **5.1 Transportation conditions**

The product may be transported in shipping containers by all modes of transport (including in heated, sealed aircraft compartments, with no distance restrictions). When transported in railcars, the shipment must be small, low-tonnage.

When transporting the product, ensure protection from dust and precipitation. Do not tilt the product.

### **5.2 Preparation for transportation**

Products must be secured to ensure stability and prevent mutual displacement and impact. Handling signs on the shipping container must be strictly observed during loading, unloading, and transportation.

## **6 DISPOSAL**

The product does not contain any hazardous or toxic substances that could harm human health or the environment and does not pose a risk to life, human health, or the environment at the end of its service

life. Therefore, the product can be disposed of according to general industrial waste disposal regulations. The precious metal content of the product's components (electronic boards, connectors, etc.) is extremely low, making recycling them impractical.

## **7 WARRANTY OBLIGATIONS**

The warranty period for the device is 12 months, counting from the date of commissioning. The warranty does not cover defects resulting from improper handling, maintenance, storage, or transportation.