



Professional weather stations

---

# USER MANUAL

# Content

<b>Professional weather stations.....</b>	<b>1</b>
<b>Introduction .....</b>	<b>3</b>
<b>1. Purpose.....</b>	<b>4</b>
<b>2. Safety requirements.....</b>	<b>4</b>
<b>3. Technical and metrological characteristics.....</b>	<b>5</b>
<b>4. Completeness.....</b>	<b>6</b>
<b>5. Main functions .....</b>	<b>6</b>
<b>6. The structure of a weather station .....</b>	<b>7</b>
<b>6.1Design and appearance.....</b>	<b>7</b>
<b>6.2Installation of a weather station .....</b>	<b>8</b>
<b>7. Maintenance.....</b>	<b>10</b>
<b>8. Manufacturer's (supplier's) warranties .....</b>	<b>10</b>

## **Introduction**

This operating manual (hereinafter referred to as the OM) contains information about the PRO line of mobile weather stations, which is necessary to ensure full use of their technical capabilities, proper operation and maintenance.

The operating manual is intended for personnel performing installation, operation, repair and maintenance of the weather station.

«Jcom-IoT» is the copyright holder for the PRO automatic weather stations. For more information, please contact us in the following ways:

Phone: +374 96 170 688

Email: [jcomiotsales@gmail.com](mailto:jcomiotsales@gmail.com)

Website: <https://jcom-iot.com/>

## 1. Purpose

PRO automatic mobile weather stations are compact professional weather stations that record a variety of environmental parameters. Installing a GPS module allows for combining GPS data with data received from a weather station, performing algorithmic calculations to measure actual wind speed and direction while moving. Thus, the mobile weather station is primarily designed to address the problem of wind speed and direction distortion.

PRO weather stations are available in various models. Depending on the model, each device has a different set of sensors and the number of parameters it can record.

The table below shows possible modifications of weather stations.

**Table 1.**PRO mobile weather station designs

Measurable parameters	Modifications of the PRO weather station				
	PRO 200M	PRO 500M	PRO 600M	PRO 700M	PRO 800M
Air temperature		*	*	*	*
Relative humidity		*	*	*	*
Wind direction	*	*	*	*	*
Wind speed	*	*	*	*	*
Atmospheric pressure		*	*	*	*
Intensity precipitation			*		
Type of precipitation				*	*
Solar radiation				*	*
UV index					*
Suspended particles PM2.5					
Suspended particles PM10					
Noise					
<b>GPS option</b>	*	*	*	*	*

## 2. Safety requirements

Before using the weather station, please read the operating documentation.

Installation and commissioning must only be carried out by qualified personnel.

Do not perform measurements or touch live equipment. Follow the equipment's technical specifications, storage conditions, and operating conditions.

If the equipment is not connected properly:

- there is a possibility that the equipment will not work;
- the equipment may fail completely;
- Under certain conditions, a risk of electric shock may occur.

### 3. Technical and metrological characteristics

Main the technical and metrological characteristics of PRO weather stations are given in Table 2.

**Table 2.**Main technical and metrological characteristics, including accuracy indicators

Name of the characteristic	Characteristic values
Air flow velocity measurement range (ultrasonic principle), m/s	from 0 to 60
Limits of permissible error in air flow velocity measurements: - absolute in the range from 0.3 to 10 m/s incl., m/s; relative in the range over 10 to 60 m/s, %	$\pm 0.3$ $\pm 3$
Sampling frequency for air flow velocity measurement, Hz	Up to 10
Air flow direction measurement range (ultrasonic principle), degrees	from 0 to 360
Limit of permissible absolute error in air flow velocity measurements, degrees	$\pm 3$
Sampling frequency when measuring air flow direction, Hz	Up to 10
Air temperature measurement range, °C	from - 50 to +80
Limit of permissible absolute error in air temperature measurements, °C	$\pm 1$ °C per year
Relative humidity measurement range, %	from 0 to 100
Limit of permissible absolute error in measurements of relative air humidity, %	$\pm 1\%$ per year
Atmospheric pressure measurement range, hPa	from 10 to 1300
Limit of permissible absolute error of atmospheric pressure measurements, hPa	$\pm 1$
Instantaneous precipitation amount, mm/s	0.4 Resolution: 0.01mm/0.1mm
Limit of permissible absolute error in precipitation intensity measurements, %	$\pm 5$
Solar radiation measurement range, W/m <sup>2</sup>	from 0 to 2000 Resolution: 1 W/m <sup>2</sup>
Limit of permissible relative error in solar radiation measurements, %	$\pm 5$
Ultraviolet radiation index indication	from 0 to 15 Resolution: 1
Measurement range of microparticle concentration (PM <sub>2.5</sub> ), µg/m <sup>3</sup>	from 0 to 1000 Resolution: 0.3 µg/m <sup>3</sup>
Limit of permissible absolute error in measuring the concentration of microparticles (PM <sub>2.5</sub> )	$\pm 15\%$ or $\pm 10$ µg/m <sup>3</sup>
Measurement range of microparticle concentration (PM <sub>10</sub> ), µg/m <sup>3</sup>	from 0 to 1000 Resolution: 0.3 µg/m <sup>3</sup>
Limit of permissible absolute error in measuring the concentration of microparticles (PM <sub>10</sub> )	$\pm 15\%$ or $\pm 10$ µg/m <sup>3</sup>
Noise level measurement range, dB	from 30 to 130 Resolution: A-scale

Limit of permissible absolute error in noise level measurements, dB	1.5
Mean time between failures, h	85,000
Service life, years	8
Terms of Use: - air temperature, °C - relative air humidity, % atmospheric pressure, hPa	from minus 50 to +80 from 0 to 100 from 300 to 1200
DC power supply voltage, V	from 9 to 30
Current consumption, mA	from 25 to 30
Degree of protection	IP66
Interface	RS485
Data transfer rate	2400, 4800, 9600, 19200 etc.
Weight, kg	No more than 1.5 kg

#### 4. Completeness

The complete set of the weather station is given in Table 3.

**Table 3** Weather station completeness

Name	Quantity, pcs.
1. Automatic mobile weather station PRO (modification depending on the order)	1
2. Operation manual for the "PRO automatic mobile weather stations"	1 per batch
3. Passport	1
4. Connecting cable 10 m	1
5. Mast mounting kit	1

#### 5. Main functions

The PRO family of weather stations is an integrated design for measuring the following meteorological parameters and air quality:

- air temperature;
- relative air humidity;
- precipitation intensity;
- amount of precipitation;
- atmospheric pressure;
- wind direction;
- wind speed;
- solar radiation, ultraviolet radiation index;
- concentration of microparticles (PM2.5, PM10).

The weather station is connected using a six-pole electrical connector with a threaded joint and a corresponding connecting cable (length 10 m).

## 6. The structure of a weather station

### 6.1 Design and appearance

The weather station is housed in a plastic case. The appearance of various versions of the PRO weather station is shown in Figure 1.

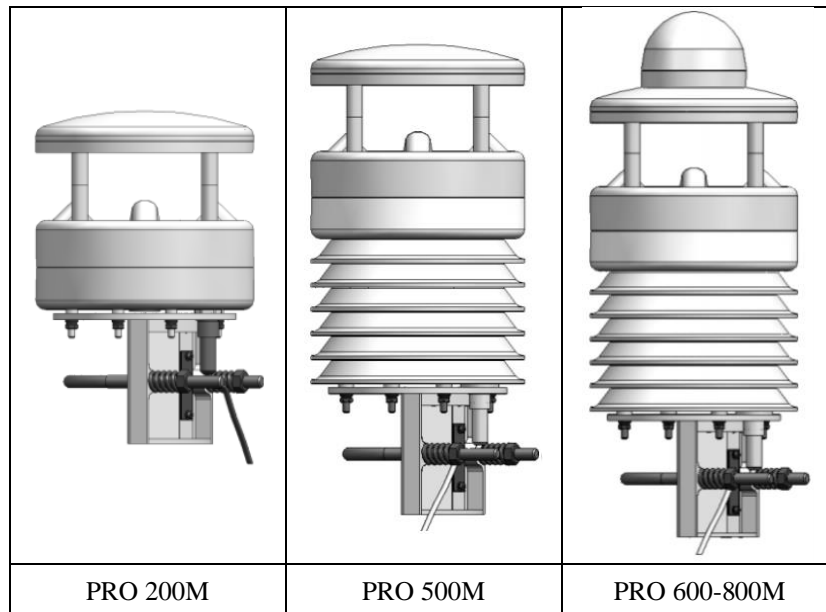

**Figure 1**– Appearance of various modifications of PRO weather stations

The location of the sensors is shown using the example of the most complete configuration of the PRO 800M weather station:

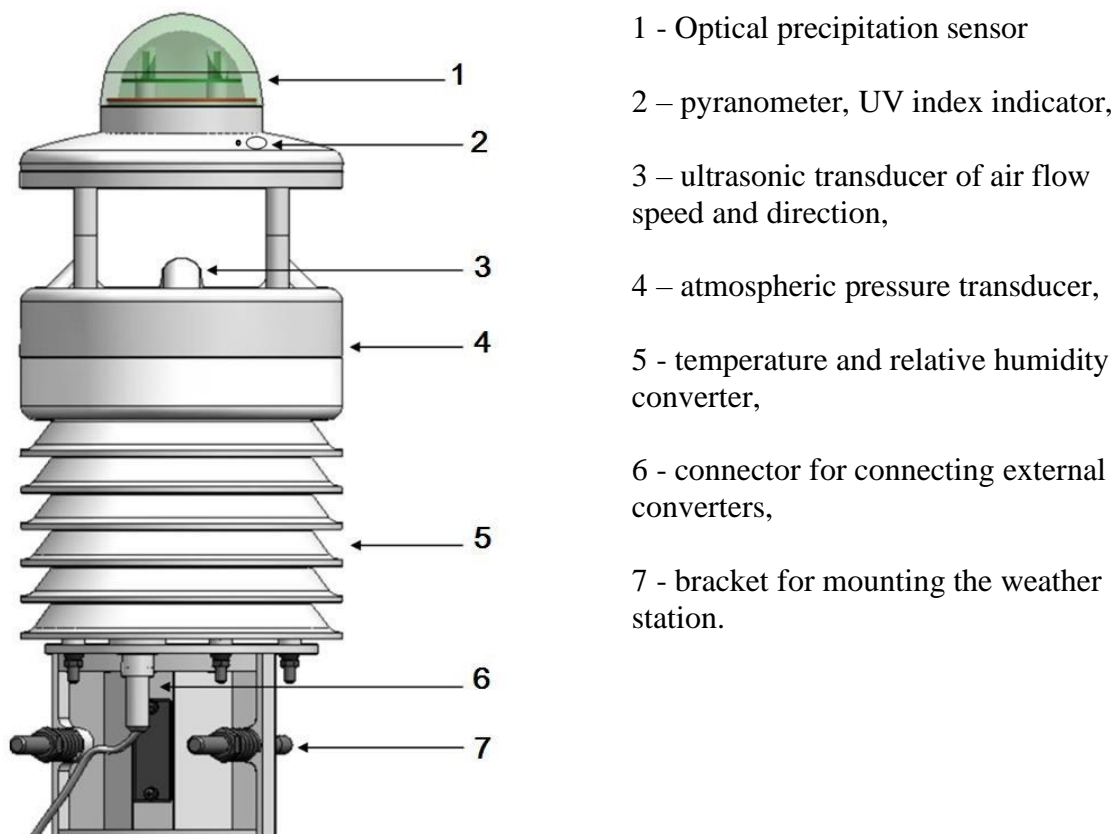

**Figure 2**– Location of sensors

## 6.2 Installation of a weather station

### 6.2.1 Selecting an installation location

To ensure a long service life and proper operation of the weather station, please pay attention to the following points when choosing an installation location:

- The weather station should be located in an open area where the equipment can be easily accessed. There should be no significant obstacles around the site where the weather station is located (large buildings, groups of trees).

- It is never recommended to install a weather station near highly heated surfaces, such as roofing felt.

- The installation site is selected in an area that is characteristic (typical) of the surrounding area and does not differ from the surrounding territory in any features of heat and moisture exchange.

- The weather station should not be located in the shade.

- The weather station is mounted on a mast above the ground. The installation height is at least 2 meters above the ground.

- A power source is required for continuous operation of the device.

**Note:** *The measured parameter values are valid only for the location where the weather station is installed. These data should not be used to draw conclusions for the entire surrounding area.*

Figure 3 shows a diagram of the installation of a weather station in an open area.

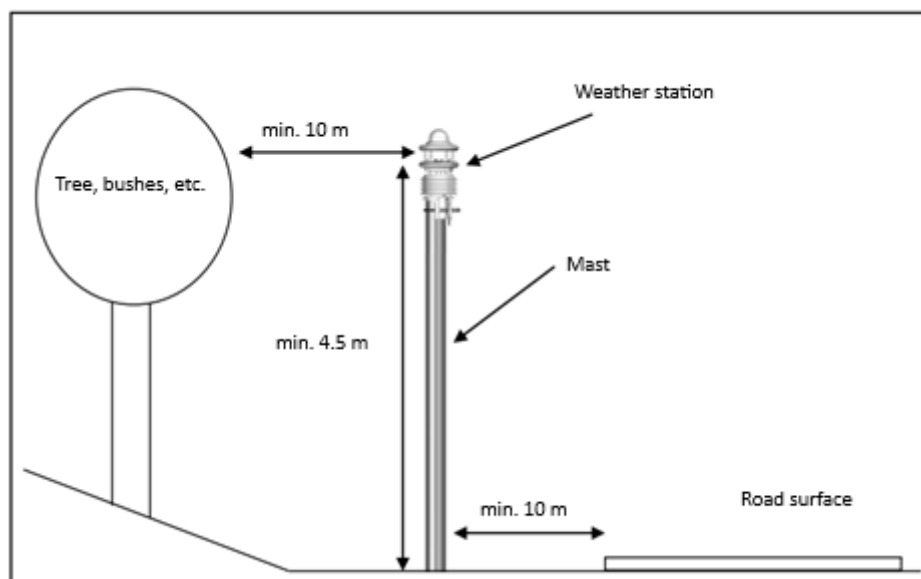

**Figure 3**– Location of the weather station in space.

### 6.2.2 Installation procedure

The device bracket is designed for installation on the top of a mast with a diameter of 5076 mm. The following tools are required for installation:

- A 13 mm spanner (open-end or box-end).
- Compass for setting the anemometer in the north direction.

The procedure for attaching the weather station to the mast is as follows:

- The nuts should be loosened.
- Install the weather station on the top of the mast.
- Tighten the nuts evenly until there is no contact with the base of the mast, but the weather station can still be moved easily.

- Point the weather station north to accurately measure wind direction.
- Tighten both nuts.

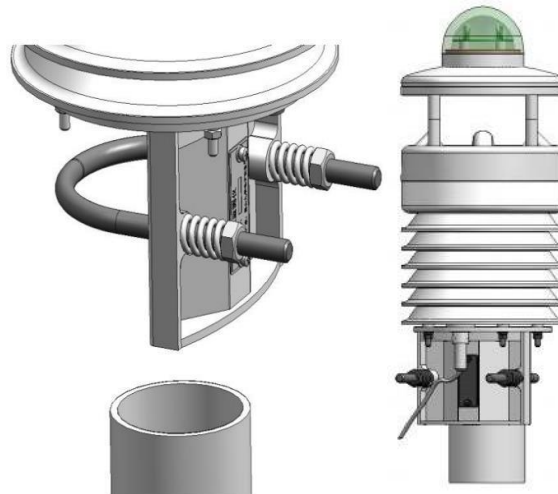

**Figure 4**– Installation of a weather station on a mast.

In order for a weather station to display accurate data, it must not only be correctly placed, but also accurately configured.

To accurately determine wind direction, the weather station must be oriented north. For this purpose, special arrows are located on the weather station body.

The sequence of actions for aligning the weather station to the north:

- If the sensor is already mounted, first loosen both nuts enough to allow the sensor to rotate easily.
- Using a compass, determine the north and fix the starting point on the horizon.
- Orient the sensor so that south and north are aligned with the north point fixed on the horizon.
- Tighten both nuts 3 turns.

### 6.2.3 Connecting power supply and interfaces

On the bottom of the weather station is a six-pin screw connector used for power supply and communication via the interfaces provided with the weather station's connecting cable. The connector is shown below, and Table 4 provides a description of the connectors.

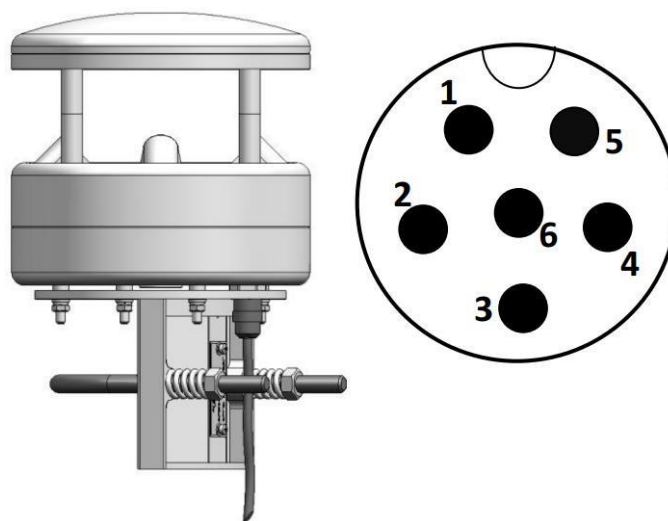

**Figure 5**– Connector for power supply and interfaces

**Table 4.**Contact designation

<b>Pin number and color</b>	<b>Purpose</b>
1 "Red"	Nutrition "+"
2 "Black"	Nutrition "-"
3 "Yellow"	RS485 (A)
4 "Blue"	RS485 (B)
5 "Gray"	Not used
6 "Pink"	Not used

The weather station requires a supply voltage of 9-30 VDC, and a current of no more than 30 mA at a standard 12 VDC. The power supply used must be certified according to the Class III (SELV) equipment protection standard. The connecting cable is marked according to DIN 47100:



*Note:* To connect the weather station connector, you need to remove the yellow plug.

When connecting the power supply, observe polarity. Incorrect heating voltage polarity, as well as reversed polarity, will damage the weather station!

## **7. Maintenance**

In principle, the equipment is maintenance-free. However, it is recommended to perform a functional check once a year. During this check, pay attention to the following:

- Visual inspection to detect contamination of the device.
- Checking the operation of sensors by polling measured values.

## **8. Manufacturer's (supplier's) warranties**

The manufacturer guarantees the product's compliance with technical specifications, provided the conditions of transportation, storage, installation, and operation are met. The warranty period is 12 months from the date of delivery of the product to the buyer.